

## ENGINE FIRE DETECTION SYSTEM - MAINTENANCE PRACTICES

### 1. General

- A. Maintenance practices for engine fire detection system consist of heat detection loop removal/installation, control box removal/installation and alarm assembly removal/installation.

### 2. Heat Detection Loop Removal/Installation

- A. Remove the Heat Detection Loop (Refer to Figure 201).

- (1) Make sure that the BATTERY switch is in the OFF position.
- (2) Remove the left and right cowl doors. Refer to Chapter 71, Engine Cowling and Nose Cap - Maintenance Practices.
- (3) Remove the screws that attach the heat detection loop mounting flange to the firewall.
- (4) Disconnect the heat detection cable electrical connectors at the fire wall.
- (5) Pull the cable through the firewall.

**CAUTION: You must be very careful during maintenance not to twist, kink or dent the sensing loop cables. Minimum radius of bends must not be less than 0.50 inch.**

- (6) For Airplane 208B2197 and Airplanes 208B5000 and On do the steps that follow:
  - (a) Loosen the quick-release fasteners on the heat detector clamps.
    - 1 Remove the heat detector loop from the clamp heat detector retainer.
  - (b) If necessary to remove the cable, near the center of the firewall and at the left aft of the engine, remove the safety wire where cable sections are connected.
    - 1 Disconnect the cable sections.
- (7) For Airplanes 20800001 and On, Airplanes 208B0001 thru 208B2196 and 208B2198 thru 208B4999 do the steps that follow:
  - (a) Remove the nuts to separate the loop section from the clamps.
    - 1 Remove the loop sections from engine compartment.
    - 2 Remove and retain insulators from loop sections.

- B. Install Heat Detection Loop (Refer to Figure 201).

- (1) Insert leads of loop through firewall.

**CAUTION: You must be very careful during maintenance not to twist, kink or dent the sensing loop cables. Minimum radius of bends must not be less than 0.50 inch.**

- (2) Attach heat detection loop mounting flange to firewall with screws. Ensure that there is a positive electrical contact between flanges and firewall.
- (3) Attach each section of loop with brackets and nuts.
- (4) For Airplane 208B2197 and Airplanes 208B5000 and On do the steps that follow:
  - (a) Connect the heat detector cables at the fire wall.
  - (b) Install the heat detector loop in its correct position in the clamp heat detector retainer.
    - 1 Tighten the quick-release fasteners on the heat detector clamps.
  - (c) If necessary, connect the heat detector sections.
    - 1 Safety the cable section connectors with wire. Refer to Chapter 20, Safelying - Maintenance Practices.
- (5) For Airplanes 20800001 and On, Airplanes 208B0001 thru 208B2196 and 208B2198 thru 208B4999 do the steps that follow:
  - (a) Connect the heat detector cables at the fire wall.
  - (b) Put the heat detector in its correct position in the clamp insulator.
  - (c) Install the nut that attaches the loop section to the clamp.
- (6) Attach the heat detection elements to engine mount assembly with clamps, and to engine flange brackets with screws using retained insulators.
- (7) Use the insulators and attach the heat detection elements to the engine flange brackets.
- (8) Connect the electrical connectors to the heat detection loop.

(9) Test the system operating the TEST switch.

(10) Install the left and right cowl doors. Refer to Chapter 71, Engine Cowling and Nose Cap - Maintenance Practices.

### 3. Control Box Removal/Installation

A. Remove the Control Box (Refer to Figure 201).

- (1) From the inside cabin section under instrument panel, remove screws securing control box to firewall.
- (2) Disconnect the control box electrical connector.
- (3) Remove the control box from the airplane.

B. Install the Control Box (Refer to Figure 201).

- (1) Install the control box to firewall and attach with the screws.
- (2) Connect the electrical connector to the control box.

### 4. Alarm Assembly Removal/Installation

A. Remove the Alarm Assembly (Refer to Figure 201).

- (1) Remove the screws that attach the alarm assembly to interior cabin top.
- (2) Disconnect the electrical connector from alarm assembly.
- (3) Remove alarm assembly from airplane.

B. Install Alarm Assembly (Refer to Figure 201).

- (1) Install the alarm assembly to the interior cabin top and attach with screws.
- (2) Connect the electrical connector to the alarm assembly.

Figure 201 : Sheet 1 : Fire Detection System

A22605

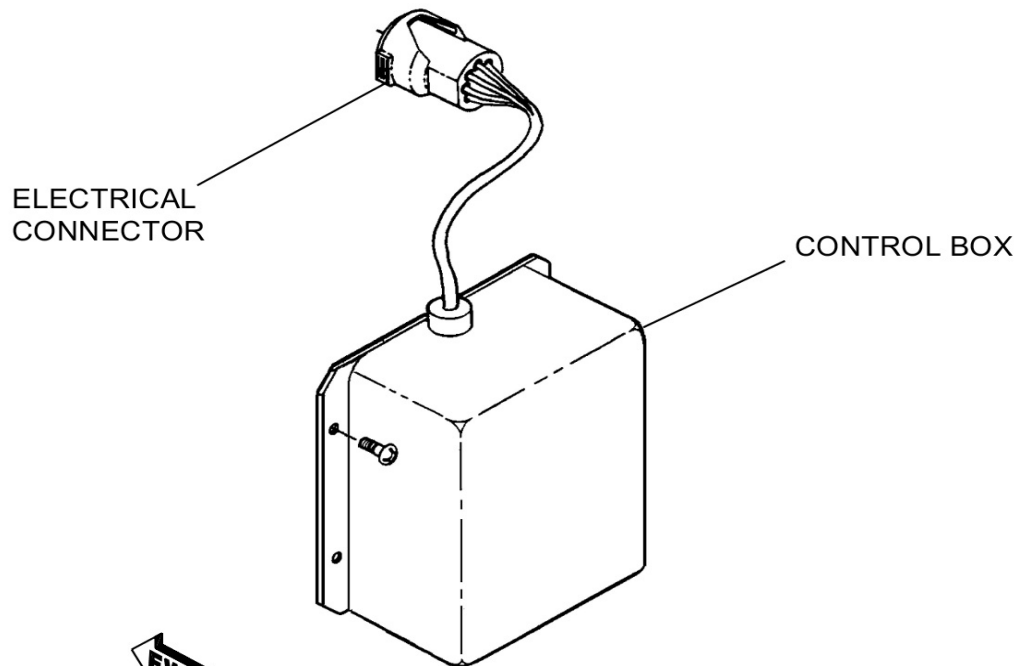
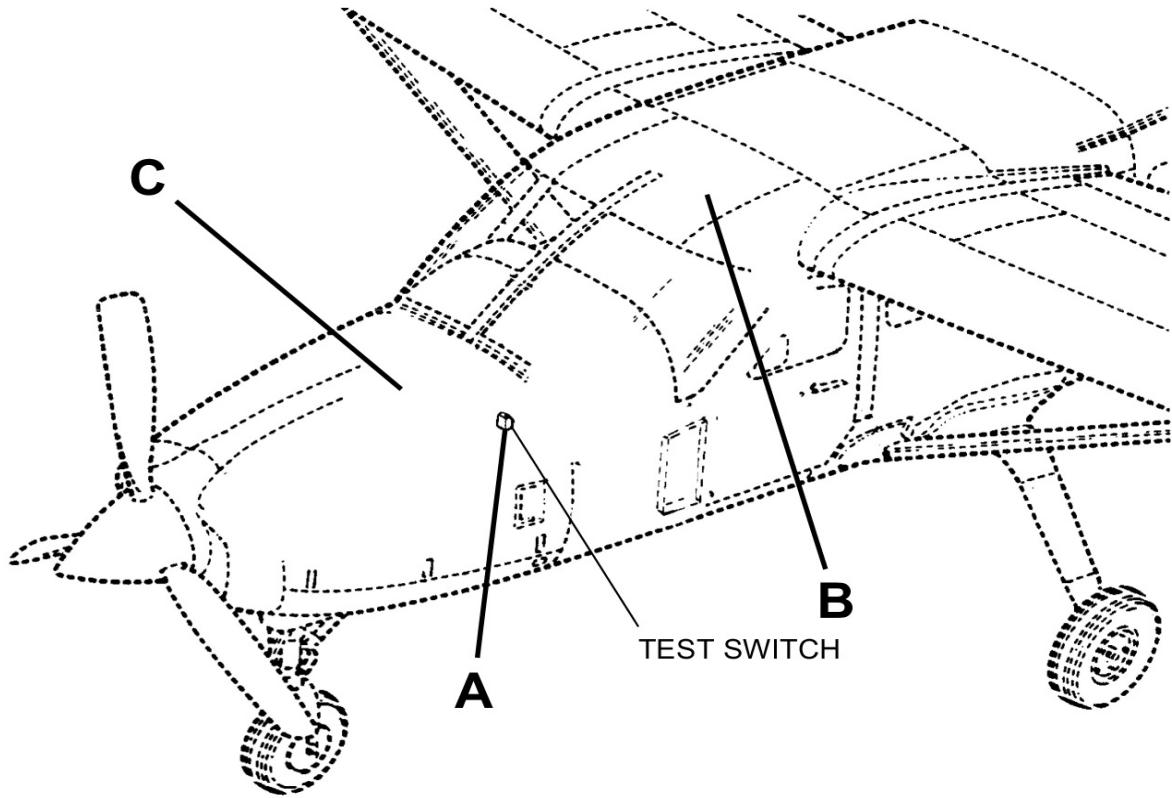

**DETAIL A**  
TYPICAL FOR ALL  
208 SERIES MODELS

2616R1021  
2616R1022

Figure 201 : Sheet 2 : Fire Detection System

A22606

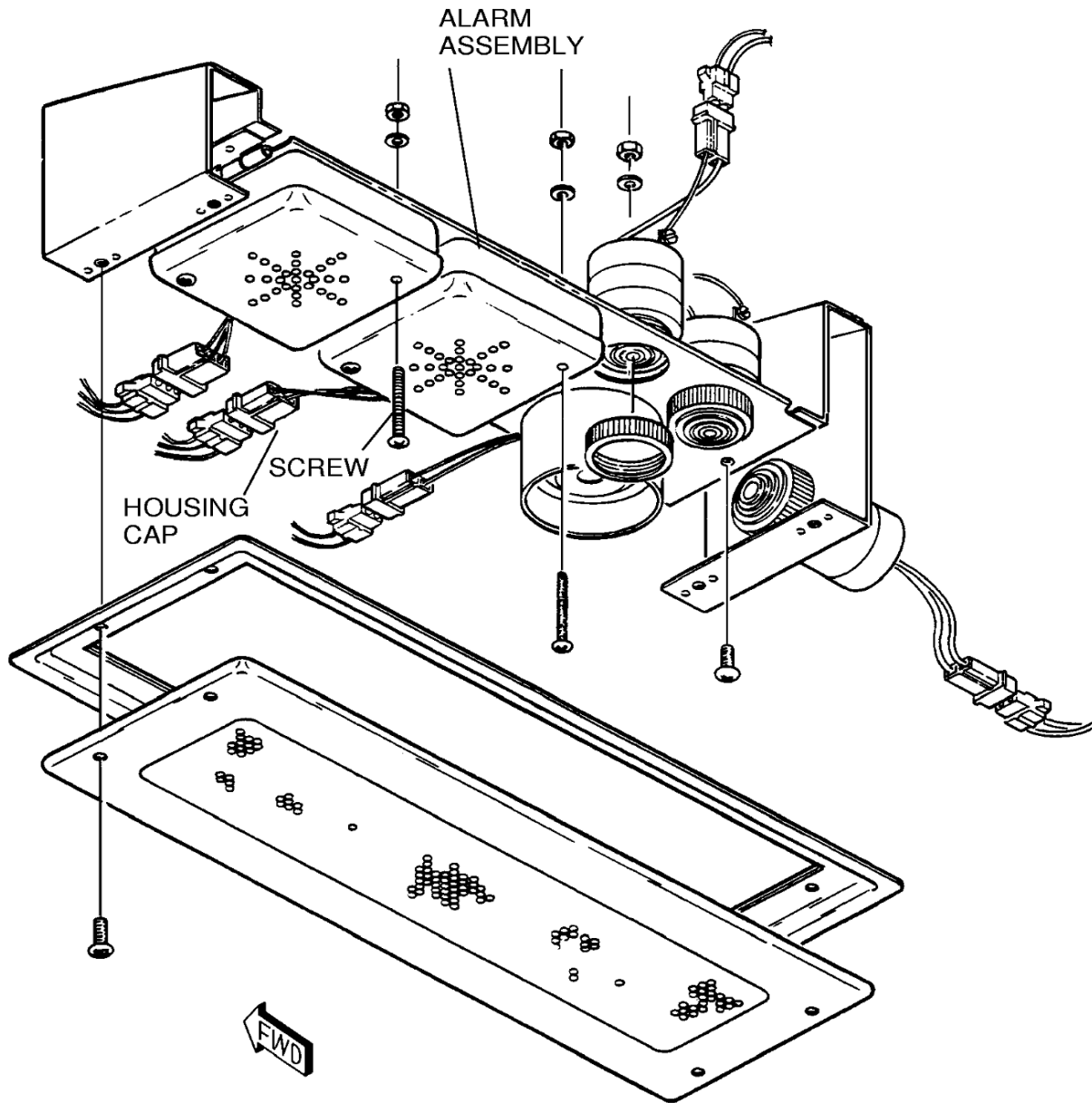

**DETAIL B**  
TYPICAL FOR ALL  
208 SERIES MODELS

B26162001

Figure 201 : Sheet 3 : Fire Detection System

A22607

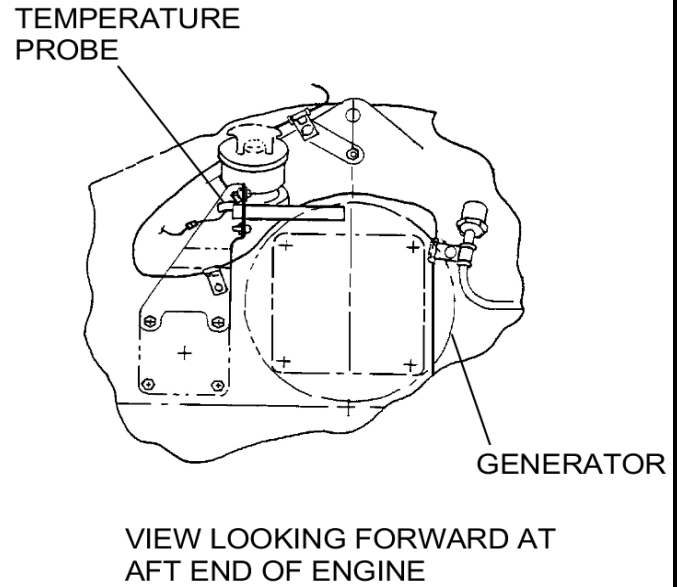
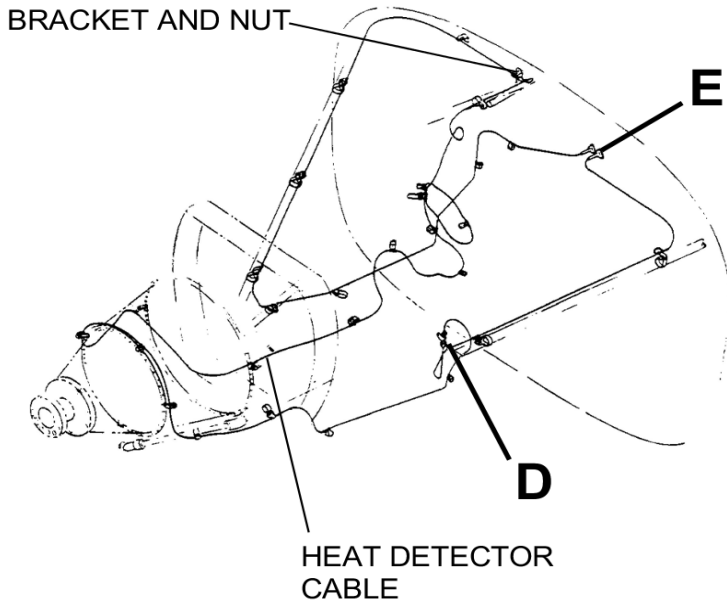

**DETAIL C**

AIRPLANES 2080001 AND ON,  
AIRPLANES 208B0001 THRU 208B2196  
AND AIRPLANES 208B2198 THRU 208B4999

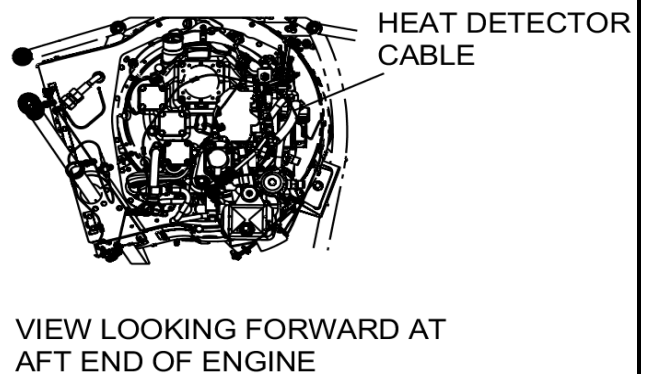
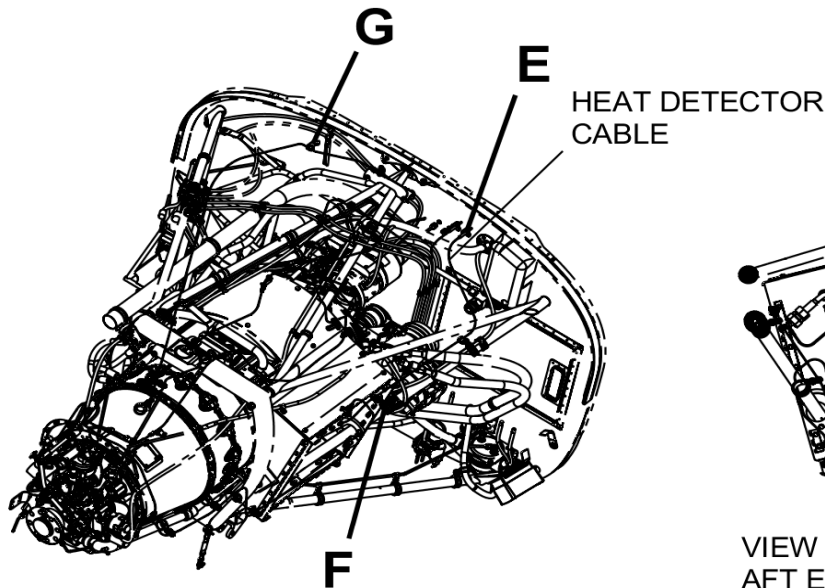

**DETAIL C**

AIRPLANES 208B2197 AND  
AIRPLANES 208B5000 AND ON

C2619R1021  
C2614T1479

Figure 201 : Sheet 4 : Fire Detection System

A89779

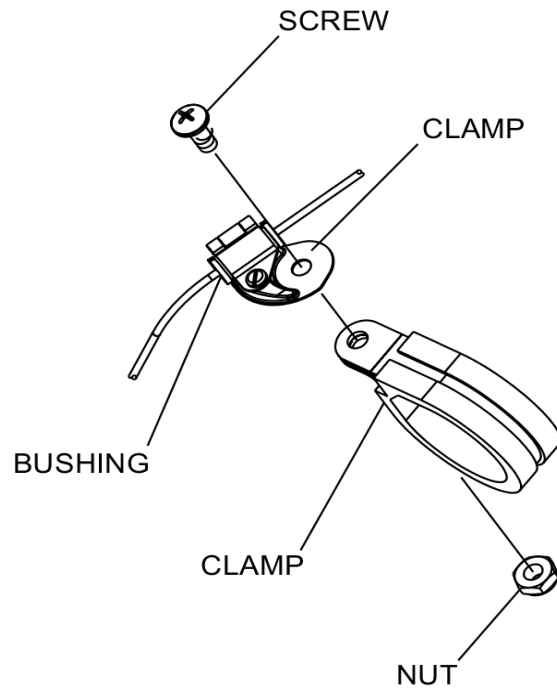
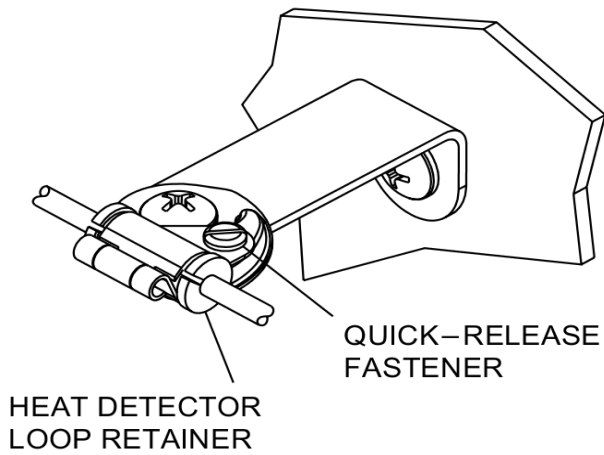
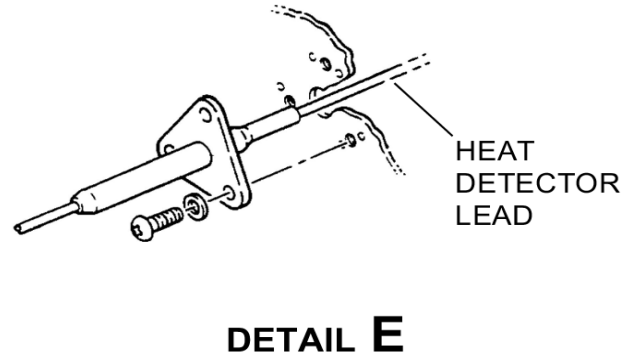
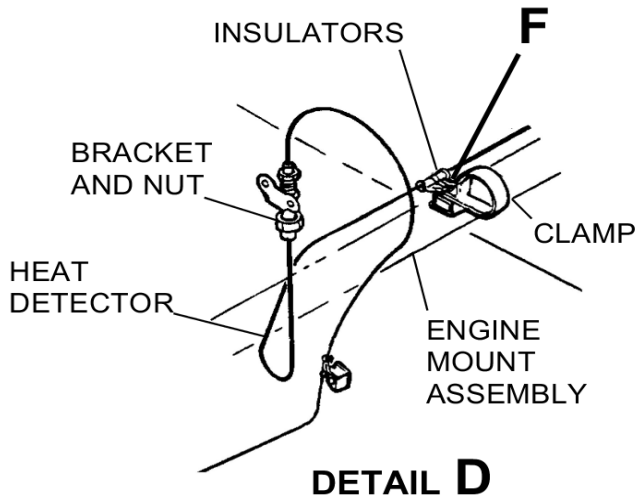

D2619R1023  
E2619R1024  
F2614T1479  
G2614T1464